

PennEngineering®

SPOTFAST® FASTENERS



BULLETIN **SF**



1107
REV. 610

SPOTFAST® FASTENERS

Allows permanent joining of two metal sections and metal to PCB/plastic panels

- Alternative to riveting and welding.
- No special installation equipment required.
- Flush mounted on both sides.
- Minimal space requirements.
- Can be installed blind into bottom (panel 2) sheet.
- Can be concealed with paints and powder coatings.



SpotFast fasteners shown actual size.

The PEM® SpotFast® self-clinching fastener creates a permanent, flush joining of two sheets. The RoHS-compliant fasteners install smooth with the top sheet, and flush or sub-flush with the bottom sheet. Squeezing the fastener into place causes a cold-flow of panel material into the fastener's two separate clinch profiles. Type SF, SFP, and SFW fasteners can attach two metal sheets too thin to weld; fasten sheets of unequal thicknesses; join dissimilar metals unable to be welded; and even attach ultra-thin metal sections. Type SFP fasteners are made from precipitation hardened stainless steel for installation into stainless steel sheets where corrosion resistance may be required. Type SFW is specifically designed to allow pivoting of two sheets of metal. A wave washer provides the consistent torsion to allow repeatable rotation.

Type SFK fasteners create a permanent, flush joining of metal to PCB/plastic panels. The fastener has two separate joining profiles. Squeezing the fastener into place causes a cold-flow of the metal panel material into the fastener's clinch profile and a broaching fit of the knurl into the PC Board or plastic panel.

Unlike rivets that "bulb" during installation, the ultimately flush profile of SpotFast fasteners allows for unobtrusive attachment requiring minimal space. A smooth surface is retained for finishing and fasteners can be concealed easily with paints or powder coatings.

PART NUMBER DESIGNATION

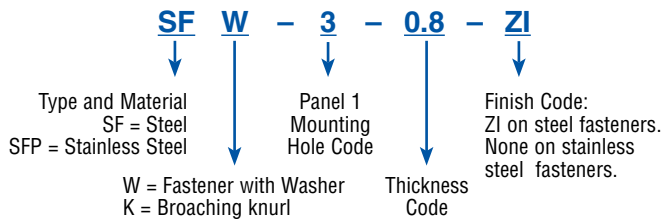

Look for the
PEM® "dimple"
trademark.

SPOTFAST® FASTENER SELECTOR GUIDE

Type	Primary Use				
	Joining two panels of similar or dissimilar metals	Joining two panels when one is stainless steel	Joining a metal panel to a PCB or plastic panel	Single point hinging applications	Offers highest corrosion resistance in product family
SF	•			• (1)	
SFP		•		• (1)	•
SFW				•	
SFK			•	• (1)	

(1) Not primary use. Can be used as hinge point if required.

METAL TO METAL



Type SF fastener installed into unequal thickness sheets. Fastener is smooth with top of panel 1.



Type SF fastener installed sub-flush with panel 2. Fastener will be flush at minimum sheet thickness.

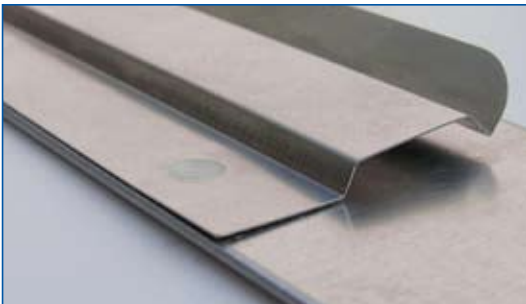

Sheets as thin as .005"/0.13mm may be attached to thicker sheets using a PEM® SpotFast® fastener. The thin sheet must be panel 1 and the "L" dimension must be equal to or less than the combined panel thicknesses.

HINGING APPLICATIONS



Type SFW fastener offers flush-mounted, smooth pivot point.

METAL TO PLASTIC

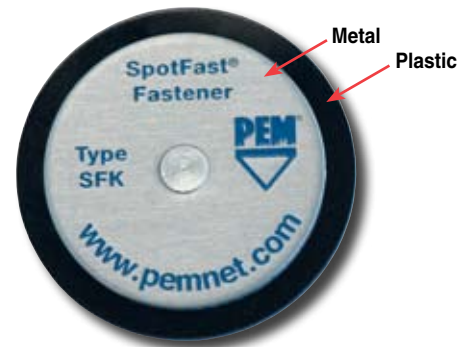

Type SFK fastener joining metal to plastic.

SPOTFAST® FASTENERS

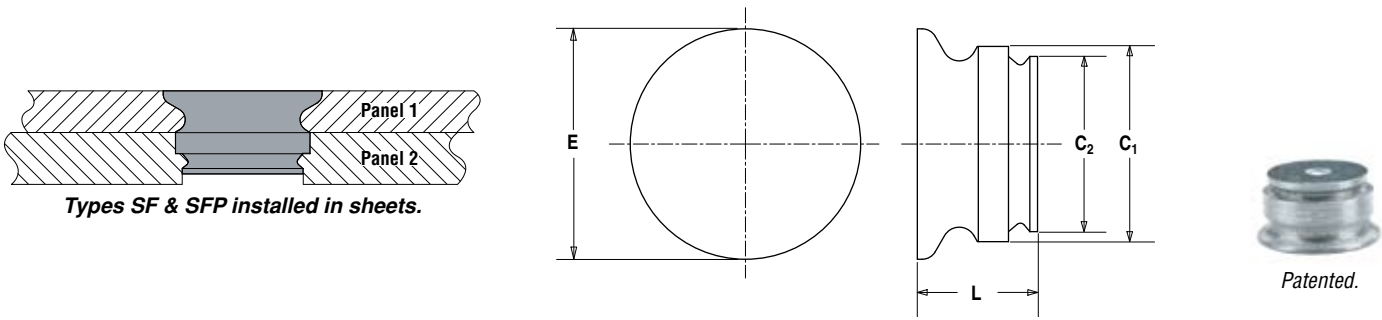

TYPE SF FOR PERMANENT JOINING OF TWO METAL SHEETS

Type and Size	Thickness Code	Panel 1				Panel 2				C ₁ Max.		C ₂ Max.		E Max.		L Max.		Min. Dist Hole To Edge	
		Thickness ±0.08mm / ±.003"		Mounting Hole +0.08mm / +.003" - .000"		Thickness Min. (1)		Mounting Hole +0.08mm / +.003" - .000"											
		mm	in.	mm	in.	mm	in.	mm	in.	mm	in.	mm	in.	mm	in.	mm	in.	mm	in.
SF-3	0.8	0.8	.031	3	.118	0.8	.031	2.5	.098	2.98	.117	2.48	.097	3.53	.139	1.5	.059	2.54	.1
SF-3	1.0	1	.039	3	.118	1	.039	2.5	.098	2.98	.117	2.48	.097	3.76	.148	1.9	.075	2.54	.1
SF-3	1.2	1.2	.047	3	.118	1.2	.047	2.5	.098	2.98	.117	2.48	.097	3.76	.148	2.31	.091	2.54	.1
SF-3	1.6	1.6	.063	3	.118	1.6	.063	2.5	.098	2.98	.117	2.48	.097	3.76	.148	3.12	.123	2.54	.1
SF-5	0.8	0.8	.031	5	.197	0.8	.031	4	.157	4.98	.196	3.97	.156	5.56	.219	1.5	.059	3.56	.14
SF-5	1.0	1	.039	5	.197	1	.039	4	.157	4.98	.196	3.97	.156	5.56	.219	1.9	.075	3.6	.14
SF-5	1.2	1.2	.047	5	.197	1.2	.047	4	.157	4.98	.196	3.97	.156	5.56	.219	2.31	.091	3.6	.14
SF-5	1.6	1.6	.063	5	.197	1.6	.063	4	.157	4.98	.196	3.97	.156	5.56	.219	3.12	.123	3.6	.14

TYPE SFP FOR INSTALLATION INTO STAINLESS STEEL

Type and Size	Thickness Code	Panel 1				Panel 2				C ₁ Max.		C ₂ Max.		E Max.		L Max.		Min. Dist Hole To Edge	
		Thickness ±0.08mm / ±.003"		Mounting Hole +0.08mm / +.003" - .000"		Thickness Min. (1)		Mounting Hole +0.08mm / +.003" - .000"											
		mm	in.	mm	in.	mm	in.	mm	in.	mm	in.	mm	in.	mm	in.	mm	in.	mm	in.
SFP-3	1.0	1	.039	3	.118	1	.039	2.5	.098	2.98	.117	2.48	.097	3.76	.148	1.9	.075	2.54	.1
SFP-3	1.2	1.2	.047	3	.118	1.2	.047	2.5	.098	2.98	.117	2.48	.097	3.76	.148	2.31	.091	2.54	.1
SFP-3	1.6	1.6	.063	3	.118	1.6	.063	2.5	.098	2.98	.117	2.48	.097	3.76	.148	3.12	.123	2.54	.1
SFP-5	1.0	1	.039	5	.197	1	.039	4.5	.177	4.98	.196	4.47	.176	5.56	.219	1.9	.075	3.6	.14
SFP-5	1.2	1.2	.047	5	.197	1.2	.047	4.5	.177	4.98	.196	4.47	.176	5.56	.219	2.31	.091	3.6	.14
SFP-5	1.6	1.6	.063	5	.197	1.6	.063	4.5	.177	4.98	.196	4.47	.176	5.56	.219	3.12	.123	3.6	.14

SPOTFAST® FASTENERS

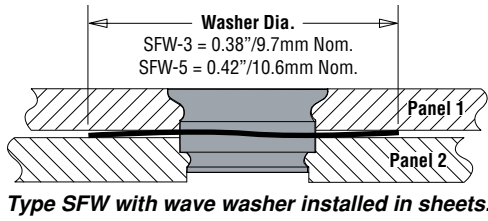

Type SFW with wave washer installed in sheets.

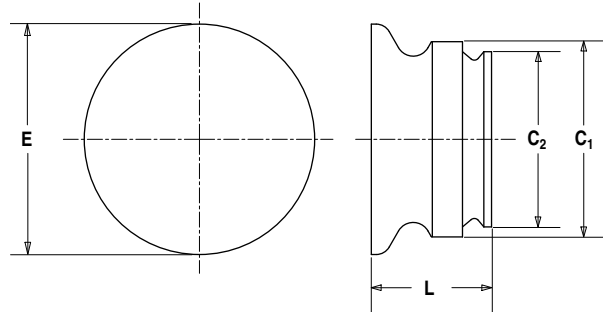

Patent pending.

TYPE SFW WITH WAVE WASHER FOR SINGLE POINT HINGING APPLICATIONS

Type and Size (2)	Thickness Code	Panel 1				Panel 2				C ₁ Max.		C ₂ Max.		E Max.		L Max.		Min. Dist Hole \varnothing To Edge	
		Thickness $\pm 0.08\text{mm} / \pm .003''$		Mounting Hole $+0.08\text{mm} / +.003'' - .000''$		Thickness Min. (1)		Mounting Hole $+0.08\text{mm} / +.003'' - .000''$											
		mm	in.	mm	in.	mm	in.	mm	in.	mm	in.	mm	in.	mm	in.	mm	in.	mm	in.
SFW-3	0.8	0.8	.031	3	.118	0.8	.031	2.5	.098	2.98	.117	2.48	.097	3.53	.139	2.09	.082	2.54	.1
SFW-3	1.0	1	.039	3	.118	1	.039	2.5	.098	2.98	.117	2.48	.097	3.76	.148	2.49	.098	2.54	.1
SFW-3	1.2	1.2	.047	3	.118	1.2	.047	2.5	.098	2.98	.117	2.48	.097	3.76	.148	2.90	.114	2.54	.1
SFW-3	1.6	1.6	.063	3	.118	1.6	.063	2.5	.098	2.98	.117	2.48	.097	3.76	.148	3.71	.146	2.54	.1
SFW-5	0.8	0.8	.031	5	.197	0.8	.031	4	.157	4.98	.196	3.97	.156	5.56	.219	1.98	.078	3.6	.14
SFW-5	1.0	1	.039	5	.197	1	.039	4	.157	4.98	.196	3.97	.156	5.56	.219	2.39	.094	3.6	.14
SFW-5	1.2	1.2	.047	5	.197	1.2	.047	4	.157	4.98	.196	3.97	.156	5.56	.219	2.79	.110	3.6	.14
SFW-5	1.6	1.6	.063	5	.197	1.6	.063	4	.157	4.98	.196	3.97	.156	5.56	.219	3.61	.142	3.6	.14

(1) Fastener will provide flush application at minimum sheet thickness. (2) Type SFW fasteners are shipped with mating washers.

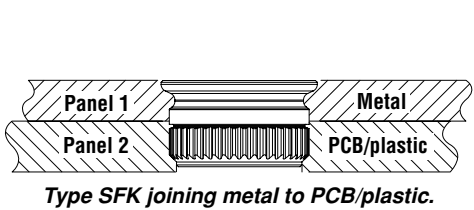

Type SFK joining metal to PCB/plastic.

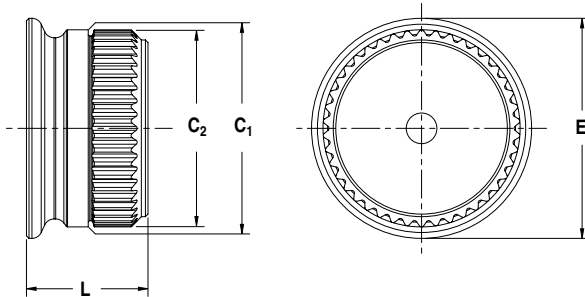

Patented.

TYPE SFK FOR JOINING METAL TO PCB/PLASTIC PANELS

Type and Size	Thickness Code	Panel 1				Panel 2				C ₁ Max.		C ₂ $\pm 0.08\text{mm} / \pm .003''$		E Max.		L Max.		Min. Dist Hole \varnothing To Edge	
		Thickness $\pm 0.08\text{mm} / \pm .003''$		Mounting Hole $+0.08\text{mm} / +.003'' - .000''$		Thickness Min. (1)		Mounting Hole $+0.08\text{mm} / +.003'' - .000''$											
		mm	in.	mm	in.	mm	in.	mm	in.	mm	in.	mm	in.	mm	in.	mm	in.	mm	in.
SFK-3	0.8	0.8	.031	3	.118	1.6	.063	2.5	.098	2.98	.117	2.9	.114	3.53	.139	2.31	.091	3	0.12
SFK-3	1.0	1	.039	3	.118	1.6	.063	2.5	.098	2.98	.117	2.9	.114	3.76	.148	2.51	.099	3	0.12
SFK-3	1.2	1.2	.047	3	.118	1.6	.063	2.5	.098	2.98	.117	2.9	.114	3.76	.148	2.72	.107	3	0.12
SFK-3	1.6	1.6	.063	3	.118	1.6	.063	2.5	.098	2.98	.117	2.9	.114	3.76	.148	3.12	.123	3	0.12
SFK-5	0.8	0.8	.031	5	.197	1.6	.063	4.5	.177	4.98	.196	4.9	.193	5.56	.219	2.31	.091	5.1	0.20
SFK-5	1.0	1	.039	5	.197	1.6	.063	4.5	.177	4.98	.196	4.9	.193	5.56	.219	2.51	.099	5.1	0.20
SFK-5	1.2	1.2	.047	5	.197	1.6	.063	4.5	.177	4.98	.196	4.9	.193	5.56	.219	2.72	.107	5.1	0.20
SFK-5	1.6	1.6	.063	5	.197	1.6	.063	4.5	.177	4.98	.196	4.9	.193	5.56	.219	3.12	.123	5.1	0.20

(1) Fastener will provide flush application at minimum sheet thickness.

MATERIAL AND FINISH SPECIFICATIONS

Type	Fastener Materials			Standard Finishes			For Use in Sheet Hardness: (2)	
	Low Carbon Steel	Carbon Steel	Precipitation Hardening Grade Stainless Steel	Passivated and/or Tested Per ASTM A380	Zinc Plated, 5µm, Colorless (1)	Zinc Plated, 5µm, Colorless with Lubricant (1)	HRB 80 / HB 150 or Less	HRB 88 / HB 183 or Less
SF	•				•		•	
SFP			•	•				•
SFW	•					•	•	
Wave washer		•			•			
SFK	•				•		•	
Part Number Code For Finishes				None	ZI	LZ		

(1) See PEM Technical Support section of our web site for related plating standards and specifications.

(2) HRB - Hardness Rockwell "B" Scale. HB - Hardness Brinell.

INSTALLATION

TYPE SF AND SFP

1. Prepare properly sized mounting hole in both panels. Do not perform any secondary operations such as deburring.
2. Place Panel 2 with smaller mounting hole on anvil and align Panel 1 mounting hole with the mounting hole of Panel 2. Place the smaller diameter end of the fastener through the mounting holes as shown in the drawing to the right.
3. With the punch and anvil surfaces parallel, apply squeezing force until the fastener is flush with the top of Panel 1.

NOTE: To use Type SF or SFP as a flush-mounted pivot point, for best results, install SpotFast fastener into Panel 1 first, then place Panel 2 over fastener and squeeze again.

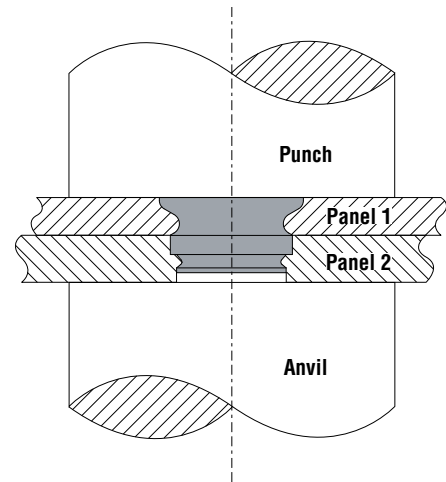

TYPE SFW

- Step 1.** Prepare properly sized mounting hole in both panels. Do not perform any secondary operations such as deburring.
- Step 2.** Using only Panel 1, with the punch and anvil surfaces parallel, apply squeezing force until the fastener is flush with the top of Panel 1.
- Step 3.** Place washer over installed fastener (concave side facing up), then place Panel 2 over fastener. Apply squeezing force. Keep .015-.020" / 0.38-0.51mm nominal gap between two sheets after installation.

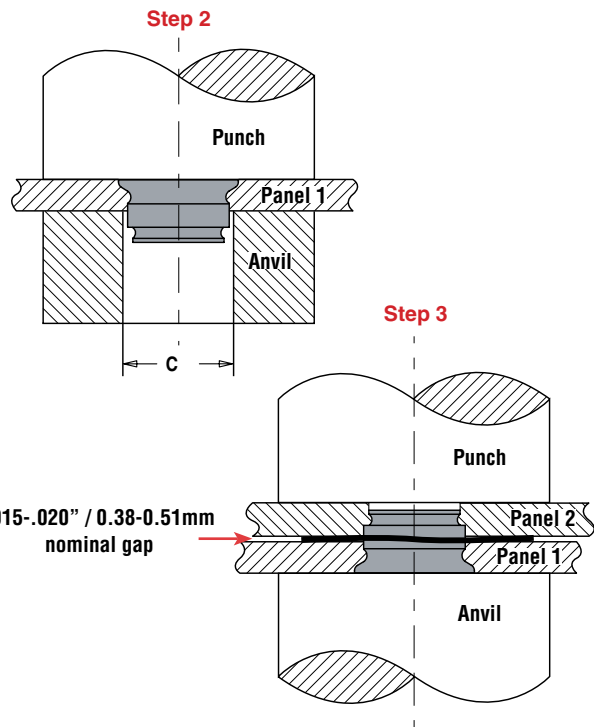

ANVIL DIMENSIONS

Size	C ±0.13/±.005 (mm) / (.in.)	Punch Part No.	Anvil Part No.*
SFW-3	3.05 / .120	975200048	970200229300
SFW-5	5.05 / .199	975200048	970200020300

* Part number for anvil used in Step 2

INSTALLATION

TYPE SFK

- Step 1.** Prepare properly sized mounting hole in both panels.
- Step 2.** Using only Panel 1, with the punch and anvil surfaces parallel, apply squeezing force until the fastener is flush with the top of Panel 1.
- Step 3.** Place Panel 2 over fastener and apply squeezing force.

ANVIL DIMENSIONS

Size	C ±0.13/±.003 (mm) / (in.)	Punch Part No.	Anvil Part No.*
SFK-3	3.05 / .120	975200048	970200229300
SFK-5	5.05 / .199	975200048	970200020300

* Part number for anvil used in Step 2

NOTE: Fastener can be installed in both sheets at once when metal panel is adequately soft compared to the non-metal panel. E-mail techsupport@pemnet.com for more information.

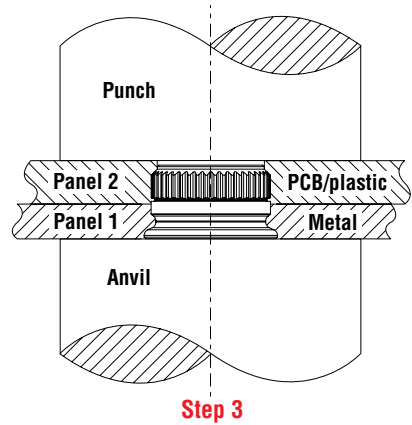
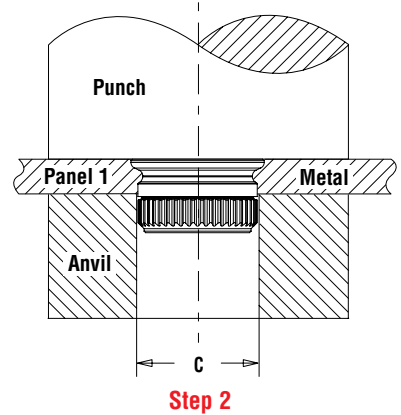

PERFORMANCE DATA⁽¹⁾

TYPE SF

Type and Size	Thickness Code	Installation				Pushout			
		Cold-rolled Steel		Aluminum		Cold-rolled Steel		Aluminum	
		kN	lbs.	kN	lbs.	N	lbs.	N	lbs.
SFW-3	0.8	8	1800	6	1350	360	80	200	45
SFW-3	1.0	9	2025	6.5	1475	525	115	250	55
SFW-3	1.2	11	2475	7	1575	555	125	310	70
SFW-3	1.6	13	2925	7.5	1700	920	205	550	125
SFW-5	0.8	11	2475	8	1800	625	140	310	70
SFW-5	1.0	12	2700	9.5	2150	800	180	515	115
SFW-5	1.2	18	4050	10	2250	1200	270	770	170
SFW-5	1.6	20	4500	12.5	2825	1500	335	1145	255

TYPE SFP

Type and Size	Thickness Code	Stainless Steel			
		Installation		Pushout	
		kN	lbs.	N	lbs.
SFP-3	1.0	13.5	3000	620	140
SFP-3	1.2	20	4500	830	186
SFP-3	1.6	22	5000	1500	340
SFP-5	1.0	18	4000	990	222
SFP-5	1.2	27	6000	1158	260
SFP-5	1.6	33	7500	3117	701

⁽¹⁾ The values reported are averages when all installation specifications and procedures are followed. Variations in mounting hole size, sheet material, and installation procedure will affect this data. Performance testing of this product in your application is recommended. We will be happy to provide samples for this purpose or perform the installation for you.

SPOTFAST® FASTENERS

PERFORMANCE DATA⁽¹⁾

TYPE SFW

Type and Size	Thickness Code	Installation into Panel 1				Installation into Panel 2				Pushout of Panel 2			
		Cold-rolled Steel		Aluminum		Cold-rolled Steel		Aluminum		Cold-rolled Steel		Aluminum	
		kN	lbs.	kN	lbs.	kN	lbs.	kN	lbs.	N	lbs.	N	lbs.
SFW-3	0.8	4.5	1010	2.5	560	3	675	2	450	350	78	85	19
SFW-3	1.0	5.5	1240	3.5	780	4.5	1010	2	450	375	84	140	31
SFW-3	1.2	6	1350	3.5	780	5	1125	2	450	500	112	250	56
SFW-3	1.6	7	1575	4	900	6	1350	2.5	560	780	175	340	76
SFW-5	0.8	7	1575	3.5	780	8	1800	4	900	350	78	270	61
SFW-5	1.0	7	1575	3.5	780	8.5	1910	5	1125	380	153	425	96
SFW-5	1.2	7	1575	4	900	8.5	1910	5	1125	925	208	510	115
SFW-5	1.6	9	2025	5	1125	10	2250	5	1125	1450	326	600	135

TYPE SFK

Type and Size	Thickness Code	Installation into Panel 1		Installation into Panel 2		Pushout of Panel 2 ⁽²⁾	
		Cold-rolled Steel		FR-4 Fiberglass			
		kN	lbs.	kN	lbs.	N	lbs.
SFK-3	0.8	6.2	1400	1.8	400	200	45
SFK-3	1.0	8	1800	1.8	400	200	45
SFK-3	1.2	8.9	2000	1.8	400	200	45
SFK-3	1.6	10.2	2300	1.8	400	200	45
SFK-5	0.8	11.1	2500	1.8	400	400	90
SFK-5	1.0	13.5	3000	1.8	400	400	90
SFK-5	1.2	15.6	3500	1.8	400	400	90
SFK-5	1.6	17.8	4000	1.8	400	400	90

(1) The values reported are averages when all installation specifications and procedures are followed. Variations in mounting hole size, sheet material, and installation procedure will affect this data. Performance testing of this product in your application is recommended. We will be happy to provide samples for this purpose or perform the installation for you.

(2) In most applications, pullout strength of the SFK fastener in Panel 1 exceeds pushout strength of Panel 2.

RoHS compliance information can be found on our website.
© 2009 PennEngineering.

Specifications subject to change without notice.
Check our website for the most current version of this bulletin.

PennEngineering®



North America: Danboro, PA USA • E-mail: info@pemnet.com • Tel: +1-215-766-8853 • Fax: +1-215-766-0143 • 800-237-4736 (USA Only)
Europe: Galway, Ireland • E-mail: europe@pemnet.com • Tel: +353-91-751714 • Fax: +353-91-753541
Asia/Pacific: Singapore • E-mail: singapore@pemnet.com • Tel: +65-6-745-0660 • Fax: +65-6-745-2400
Shanghai, China • E-mail: china@pemnet.com • Tel: +86-21-5868-3688 • Fax: +86-21-5868-3988

Visit our PEMNET™ Resource Center at www.pemnet.com