

**NEW!**



SPINNING

CLINCH BOLT

# BULLETIN



# SCB

907

Revised 909



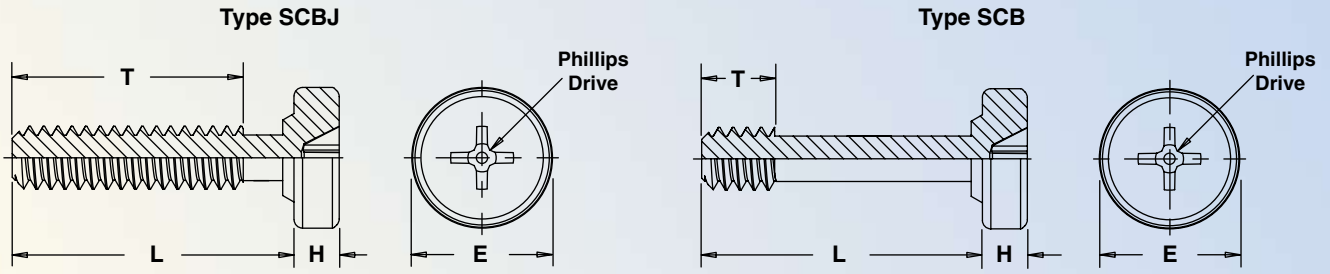

All dimensions are in inches.

UNIFIED	Thread Size	Type		Thread Code	Length Code "L" $\pm 0.015$ Length Code in 16ths of an inch			Min. Sheet Thickness	Hole Size in Sheet $+0.003 -0.000$	E $\pm 0.010$	H Nom.	T Nom.			Driver Size	Min. Dist. Hole C/L To Edge
		Jacking	Non-jacking		.250	.375	.500					-4	-6	-8		
	.112-40 (#4-40)	SCBJ	—	440	4	6	8	.040	.112	.250	.080	.160	.285	.410	#1	.130
		—	SCB		NA	NA	8					NA	NA	.130		
	.138-32 (#6-32)	SCBJ	—	632	4	6	8	.040	.138	.291	.080	.160	.285	.410	#2	.150
		—	SCB		NA	NA	8					NA	NA	.130		

All dimensions are in millimeters.

METRIC	Thread Size x Pitch	Type		Thread Code	Length Code "L" $\pm 0.4$ Length Code in millimeters			Min. Sheet Thickness	Hole Size in Sheet $+0.08$	E $\pm 0.25$	H Nom.	T Nom.			Driver Size	Min. Dist. Hole C/L To Edge
		Jacking	Non-jacking		-6	-10	-12									
	M3 x 0.5	SCBJ	—	M3	6	10	12	1.02	3	6.6	2.03	3.7	7.7	9.7	#1	3.3
		—	SCB		NA	NA	12					NA	NA	3.3		
	M4 x 0.7	SCBJ	—	M4	6	10	12	1.02	4	8.28	2.03	3.7	7.7	9.7	#2	5
		—	SCB		NA	NA	12					NA	NA	3.3		

(NA) Not Available.

## MATERIAL & FINISH SPECIFICATIONS

**MATERIAL:** Heat-treated Carbon Steel

**FINISH:** Standard: ZI - Zinc plated, 5 $\mu$ m, colorless <sup>(1)</sup>

**FOR USE IN SHEET HARDNESS:** HRB 80 (Hardness Rockwell "B" Scale) / HB 150 (Hardness Brinell) or less

(1) See PEM Technical Support section of our web site for related plating standards and specifications.

# INSTALLATION

1. Punch or drill properly sized mounting hole in sheet.
2. Place the fastener through mounting hole and into anvil. A flat or recessed punch can be used.
3. With punch and anvil surfaces parallel, apply squeezing force to the top of the screw head and the underside of the sheet material. The squeezing action forces the shoulder of the screw into the sheet, displacing sheet material, causing it to fill the void under the head and shoulder of the screw.

All dimensions are in inches.

UNIFIED	Thread Code	Anvil Dimensions		
		C	E	H
	440	.113 - .116	.270 - .280	.073 - .074
	632	.139 - .142	.308 - .318	.073 - .074

All dimensions are in millimeters.

METRIC	Thread Code	Anvil Dimensions		
		C	E	H
	M3	3.03 - 3.11	6.86 - 7.11	1.85 - 1.88
	M4	4.03 - 4.11	8.53 - 8.79	1.85 - 1.88

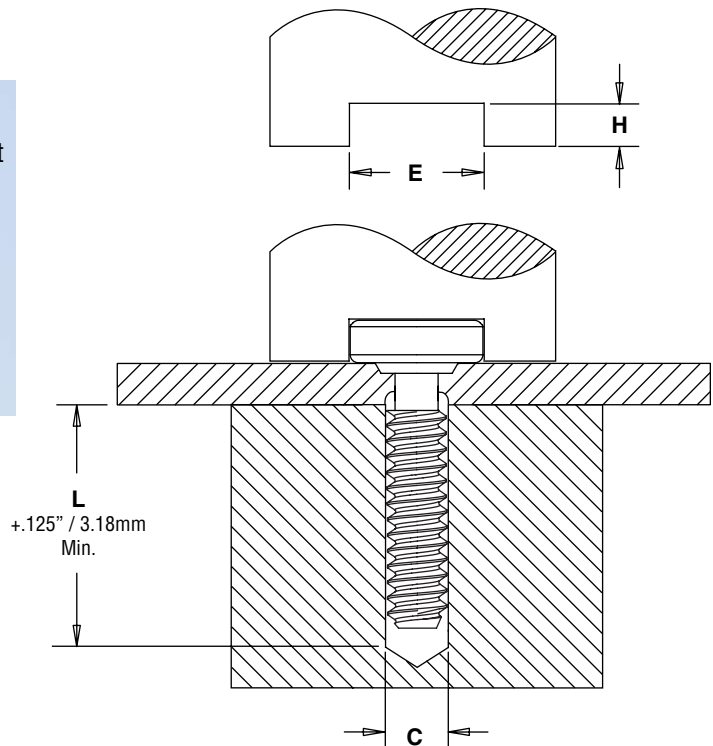

# PERFORMANCE DATA<sup>(1)</sup>

UNIFIED	Type	Thread Code	Max. Rec. Tightening Torque (in. lbs.)	Test Sheet Material					
				5052-H34 Aluminum			Cold-rolled Steel		
				Installation (lbs.)	Pushout (lbs.)	Pull Thru (lbs.)	Installation (lbs.)	Pushout (lbs.)	Pull Thru (lbs.)
	SCB / SCBJ	440	5	1900	130	590	2600	145	590
	SCB / SCBJ	632	9	2000	175	990	3500	200	990

METRIC	Type	Thread Code	Max. Rec. Tightening Torque (N • m)	Test Sheet Material					
				5052-H34 Aluminum			Cold-rolled Steel		
				Installation (kN)	Pushout (N)	Pull Thru (N)	Installation (kN)	Pushout (N)	Pull Thru (N)
	SCB / SCBJ	M3	0.74	8	580	3400	12	650	3400
	SCB / SCBJ	M4	1.7	10	1000	5700	17	1150	5700

(1) Performance values reported are averages when all installation specifications and procedures are followed. Variations in mounting hole size, panel material and installation procedure will affect this data. Performance testing of this product in your application is recommended. We will be happy to provide samples for this purpose.

RoHS compliance information can be found on our website.  
© 2009 PennEngineering.

Specifications subject to change without notice.  
Check our website for the most current version of this bulletin.

**PennEngineering®**



**North America:** Danboro, PA USA • E-mail: info@pemnet.com • Tel: +1-215-766-8853 • Fax: +1-215-766-0143 • 800-237-4736 (USA Only)  
**Europe:** Galway, Ireland • E-mail: europe@pemnet.com • Tel: +353-91-751714 • Fax: +353-91-753541  
**Asia/Pacific:** Singapore • E-mail: singapore@pemnet.com • Tel: +65-6-745-0660 • Fax: +65-6-745-2400  
 Shanghai, China • E-mail: china@pemnet.com • Tel: +86-21-5868-3688 • Fax: +86-21-5868-3988

Visit our PEMNET™ Resource Center at [www.pemnet.com](http://www.pemnet.com)