

PennEngineering®

NYLON INSERT SELF-LOCKING FASTENERS



BULLETIN

PL



# NYLON INSERT SELF-LOCKING FASTENERS

## ***Effective mounting for reusable locking threads.***

The thread locking torque performance of Type PL and PLC PEMHEX® self-clinching fasteners is equivalent to applicable NASM25027 specifications. A nylon hexagonal element provides a reusable, non-metallic prevailing torque thread lock. The strong knurled collar receives the installation force and resists torque. The spin resistance of the knurl greatly exceeds the torque that can be exerted by the self-locking feature. As the knurled collar is embedded in the sheet, the undercut cavity beneath the collar is filled with displaced sheet material, thereby captivating the fastener in the sheet.

Type CFN broaching fasteners are available for thinner sheet, close-to-edge applications. The locking element provides prevailing torque to eliminate loosening of mating threaded hardware.

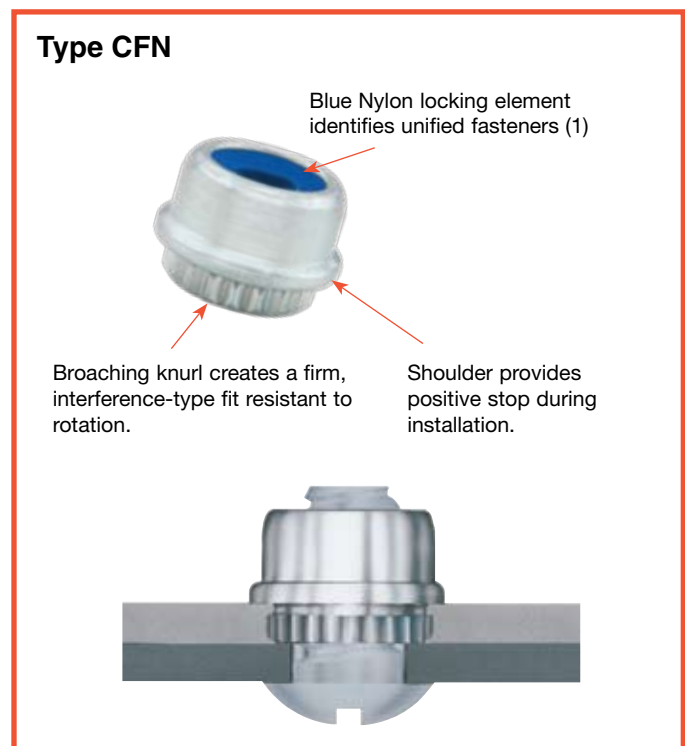

(1) The color blue for fastener locking elements is a registered trademark. Unified fasteners have a blue nylon locking element and metric fasteners have a black nylon locking element.

# NYLON INSERT SELF-LOCKING FASTENERS

## TYPES PL AND PLC

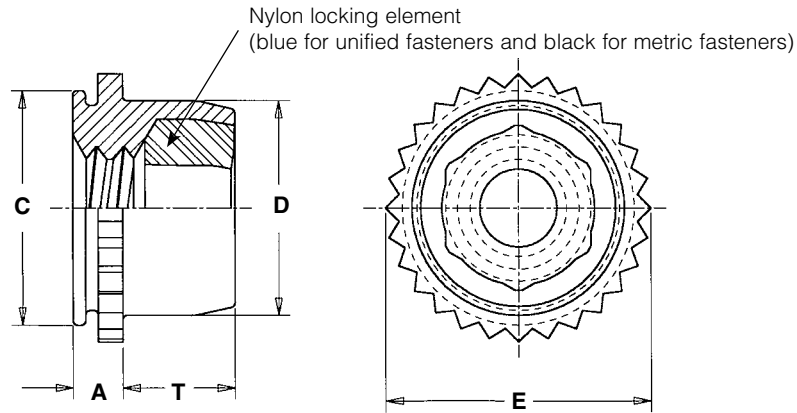

All dimensions are in inches.

UNIFIED	Thread Size	Type		Thread Code	A (Shank) Max.	Sheet Thickness (1) (2)	Hole Size In Sheet +.003 -.000	C Max.	D Max.	E Max.	T Max.	Min. Dist. Hole $\varnothing$ To Edge	Max. Hole In Attached Parts
		Fastener Material											
		Steel	Stainless Steel										
	.112-40 (#4-40)	PL	PLC	440	.060	.060 - .070	.234	.233	.215	.274	.130	.170	.132
	.138-32 (#6-32)	PL	PLC	632	.060	.060 - .070	.265	.264	.246	.305	.130	.190	.158
	.164-32 (#8-32)	PL	PLC	832	.060	.060 - .070	.297	.296	.278	.338	.155	.220	.184
	.190-32 (#10-32)	PL	PLC	032	.060	.060 - .070	.312	.311	.293	.353	.165	.250	.210

All dimensions are in millimeters.

METRIC	Thread Size x Pitch	Type		Thread Code	A (Shank) Max.	Sheet Thickness (1) (2)	Hole Size In Sheet +0.08	C Max.	D Max.	E Max.	T Max.	Min. Dist. Hole $\varnothing$ To Edge	Max. Hole In Attached Parts
		Fastener Material											
		Steel	Stainless Steel										
	M3 x 0.5	PL	PLC	M3	1.53	1.53 - 1.78	6	5.98	5.52	7.01	3.56	4.32	3.5
	M4 x 0.7	PL	PLC	M4	1.53	1.53 - 1.78	7.5	7.48	7.01	8.54	4.2	5.59	4.5
	M5 x 0.8	PL	PLC	M5	1.53	1.53 - 1.78	8	7.98	7.52	9	4.45	6.35	5.5

(1) Can be used in panel thickness of .040" to .060" / 1 mm to 1.53 mm provided the fastener is not fully installed. The knurled collar must be left protruding above the sheet to the degree that the sheet thickness is less than .060" / 1.53 mm. See installation instructions on page PL-5.

(2) Knurled collar may fracture if fastener is used in sheets thicker than .070" / 1.78 mm and screw is tightened beyond maximum tightening torque.

### PART NUMBER DESIGNATION

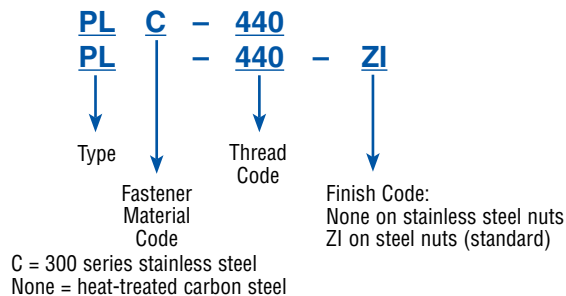

# NYLON INSERT SELF-LOCKING FASTENERS

## TYPE CFN

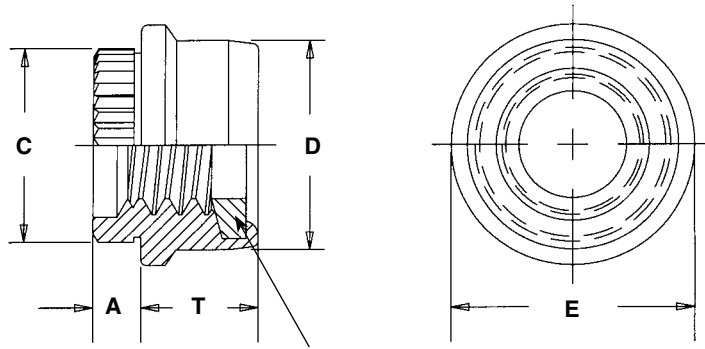

Nylon locking element  
(blue for unified fasteners and black for metric fasteners)

All dimensions are in inches.

UNIFIED	Thread Size	Type	Thread Code	Shank Code	A (Shank) ±.003	Min. Sheet Thickness	Hole Size In Sheet +.003 -.000	C ±.002	D ±.004	E +.001 -.004	T Max.	Min. Dist. Hole To Edge
	.112-40 (#4-40)	CFN	440	1	.040	.043	.152	.162	.175	.203	.104	.115

All dimensions are in millimeters.

METRIC	Thread Size x Pitch	Type	Thread Code	Shank Code	A (Shank) ±0.08	Min. Sheet Thickness	Hole Size In Sheet +0.08	C ±0.05	D ±0.1	E +0.03 -0.1	T Max.	Min. Dist. Hole To Edge
	M3 x 0.5	CFN	M3	1	1.02	1.1	3.86	4.11	4.45	5.16	2.65	2.93

## PART NUMBER DESIGNATION

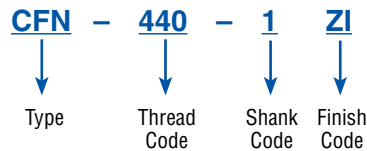

## MATERIAL AND FINISH SPECIFICATIONS

Type	Threads	Max. Temperature Limit	Fastener Material				Standard Finishes (1)		Optional Finish (1)	For Use in Sheet Hardness: (2)	
	Internal, ASME B1.1 2B / ASME B1.13M 6H	250° F / 120° C	Heat-treated Carbon Steel	Carbon Steel	300 Series Stainless Steel	Locking Element: Blue or Black Nylon	Zinc Plated, 5µm, Colorless	Passivated and / or Tested Per ASTM A380	Zinc Plated, 5µm, Yellow	HRB 60 / HB 107 or Less	HRB 70 / HB 125 or Less
PL	•	•	•			•	•	•		•	
PLC	•	•			•	•		•		•	
CFN	•	•		•		•	•	•	•	•	
Part Number Finish Code							ZI	None	ZC		

(1) See PEM Technical Support section of our web site for related plating standards and specifications.

(2) HRB - Hardness Rockwell "B" Scale. HB - Hardness Brinell.

# NYLON INSERT SELF-LOCKING FASTENERS

## INSTALLATION

### TYPES PL AND PLC

Sheet thickness .060" to .070" / 1.53 mm to 1.78 mm

1. Prepare properly sized mounting hole in sheet. Do not perform any secondary operations such as deburring.
2. Insert fastener into the anvil hole (preferably the punch side) and place the mounting hole over the shank of the fastener as shown in drawing.
3. With the punch and anvil surfaces parallel, apply a squeezing force until the knurled collar is flush with the top sheet.

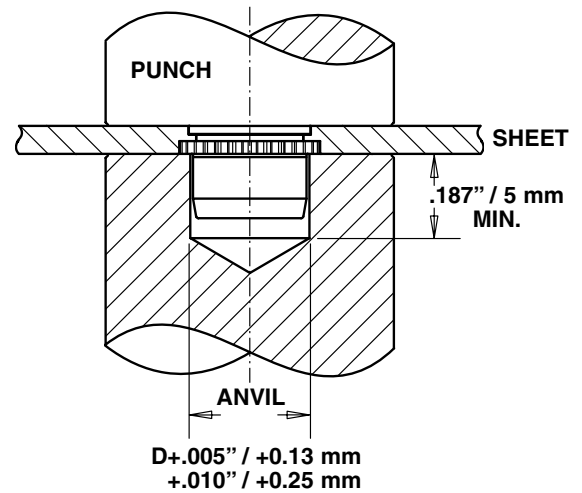

### TYPES PL AND PLC

Sheet thickness .040" to .060" / 1 mm to 1.53 mm

1. Prepare properly sized mounting hole in sheet. Do not perform any secondary operations such as deburring.
2. Insert fastener into the anvil hole (preferably the punch side) and place the mounting hole over the shank of the fastener as shown in drawing.
3. With the punch and anvil surfaces parallel, apply a squeezing force until the fastener shank is flush with the underside of the sheet. This should be accomplished by setting the depth of the counterbore in the anvil to the difference between the "A" dimension and the sheet thickness\*. When this method is used, care must be taken to protect the fastener against crushing which would damage the threads. This method will also result in reduced pushout and torque-out values.

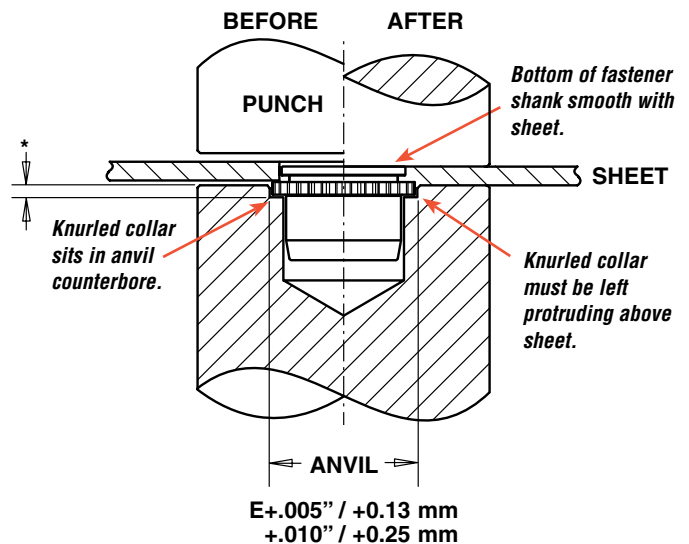

### TYPE CFN

1. Prepare properly sized mounting hole in sheet. Do not perform any secondary operations such as deburring.
2. Insert fastener into the anvil hole (preferably the punch side) and place the mounting hole over the shank of the fastener as shown in drawing.
3. Apply squeezing force until the shoulder of the fastener contacts the sheet.

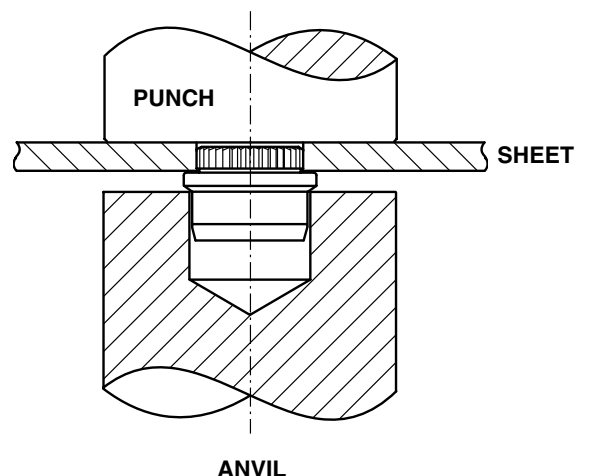

#### PEMSERTER® PRESSES

For best results we recommend using a PEMSERTER® press for either manual or automatic installation of PEM PL, PLC, and CFN fasteners. For more information on our line of presses call 1-800-523-5321 (USA only).

# NYLON INSERT SELF-LOCKING FASTENERS

## PERFORMANCE DATA<sup>(1)</sup>

### FOR TYPES PL AND PLC<sup>(2)</sup>

UNIFIED	Thread Code	Max. Rec. Tightening Torque (in. lbs.)	(3) Locking Torque (in. lbs.)	Test Sheet Material											
				.060" 5052-H34 Aluminum			.040" 5052-H34 Aluminum			.060" Cold-rolled Steel			.048" Cold-rolled Steel		
				Installation (lbs.)	Pushout (lbs.)	Torque-out (in. lbs.)	Installation (lbs.)	Pushout (lbs.)	Torque-out (in. lbs.)	Installation (lbs.)	Pushout (lbs.)	Torque-out (in. lbs.)	Installation (lbs.)	Pushout (lbs.)	Torque-out (in. lbs.)
				440	9.3	.5 to 5	2000	225	20	1500	160	20	3000	260	20
632	12.9	1 to 10	2000	285	30	1500	180	25	3000	290	30	3000	270	30	
832	19.1	1.5 to 15	2000	290	60	1500	180	28	3000	290	60	3000	270	60	
032	26.0	2 to 18	2000	300	70	1500	180	40	3000	350	70	3000	310	70	

METRIC	Thread Code	Max. Rec. Tightening Torque (N•m)	Locking Torque (N•m)	Test Sheet Material											
				1.5 mm 5052-H34 Aluminum			1 mm 5052-H34 Aluminum			1.5 mm Cold-rolled Steel			1.2 mm Cold-rolled Steel		
				Installation (kN)	Pushout (N)	Torque-out (N • m)	Installation (kN)	Pushout (N)	Torque-out (N • m)	Installation (kN)	Pushout (N)	Torque-out (N • m)	Installation (kN)	Pushout (N)	Torque-out (N • m)
				M3	1.13	.056 to .56	8.9	1000	2.25	6.67	710	2.25	13.34	1156	2.25
M4	2.3	.169 to 1.69	8.9	1290	6.77	6.67	800	3.16	13.34	1290	6.77	13.34	1200	6.77	
M5	3.12	.226 to 2.03	8.9	1330	7.9	6.67	800	4.51	13.34	1557	7.9	13.34	1380	7.9	

### FOR TYPE CFN

UNIFIED	Thread Code	Max. Rec. Tightening Torque (in. lbs.)	(4) Locking Torque (in. lbs.)	Test Sheet Material		
				.040" Cold-rolled Steel		
				Installation (lbs.)	Pushout (lbs.)	Torque-out (in. lbs.)
440	5	0.38 to 3	1000	10	4	

METRIC	Thread Code	Max. Rec. Tightening Torque (N•m)	(4) Locking Torque (N•m)	Test Sheet Material		
				1mm Cold-rolled Steel		
				Installation (kN)	Pushout (N)	Torque-out (N•m)
M3	0.75	0.042 to 0.339	4.45	44.5	0.45	

(1) The values reported are averages when all installation specifications and procedures are followed. Variations in mounting hole size, sheet material, and installation procedure will affect this data. Performance testing of this product in your application is recommended. We will be happy to provide samples for this purpose.

(2) For types PL and PLC fasteners, thread locking performance is equivalent to applicable NASM25027 specifications. Consult document PEM-REF25027 for details.

(3) The maximum locking torque and the minimum breakaway will fall within these values for the first fifteen cycles when tested in accordance with the locking torque test procedure specified in NASM25027.

(4) The maximum locking torque and the minimum breakaway will fall within these values for the first cycle.

RoHS compliance information can be found on our website.  
© 2010 PennEngineering.

Specifications subject to change without notice.  
Check our website for the most current version of this bulletin.

**PennEngineering**<sup>®</sup>



**North America:** Danboro, PA USA • E-mail: info@pemnet.com • Tel: +1-215-766-8853 • Fax: +1-215-766-0143 • 800-237-4736 (USA Only)

**Europe:** Galway, Ireland • E-mail: europe@pemnet.com • Tel: +353-91-751714 • Fax: +353-91-753541

**Asia/Pacific:** Singapore • E-mail: singapore@pemnet.com • Tel: +65-6-745-0660 • Fax: +65-6-745-2400  
Shanghai, China • E-mail: china@pemnet.com • Tel: +86-21-5868-3688 • Fax: +86-21-5868-3988

Visit our PEMNET™ Resource Center at [www.pemnet.com](http://www.pemnet.com)