

ATLAS® TYPE AEK MONEL® INSERTS

SpinTite® - Minimized-profile head

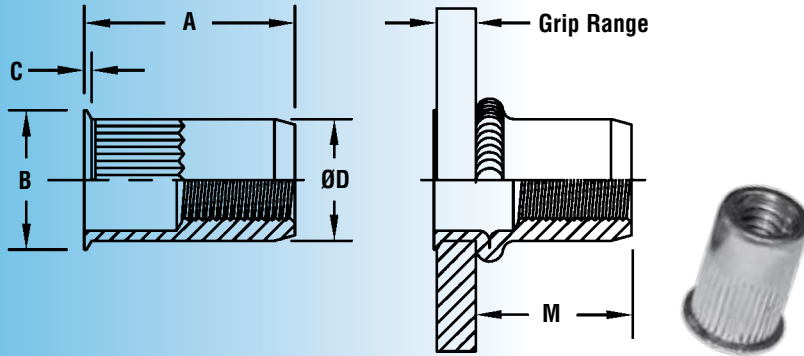

Features and Benefits

- Superior corrosion resistance.
- Feature a large diameter, low-profile head and knurled shank.
- Offers highest all around strength.
- Excellent for use in food and medical industries and marine and chemical processing environments.
- Installed with spin/spin tooling.

All dimensions are in inches.

Thread Size	Part Number	Grip Range	A ±.015	B ±.015	C Nom.	ØD Max.	M Ref.	Hole Size In Sheet +.006 -.000
#6-32	AEKM6-632-80	.020 - .080	.420	.310	.019	.265	.305	.266
#6-32	AEKM6-632-130	.080 - .130	.470	.310	.019	.265	.305	.266
#8-32	AEKM6-832-80	.020 - .080	.420	.310	.019	.265	.305	.266
#8-32	AEKM6-832-130	.080 - .130	.470	.310	.019	.265	.305	.266
#10-32	AEKM6-1032-120	.020 - .120	.475	.340	.019	.296	.315	.297
#10-32	AEKM6-1032-225	.130 - .225	.585	.340	.019	.296	.315	.297
1/4-20	AEKM6-420-165	.027 - .165	.580	.455	.022	.390	.380	.391
1/4-20	AEKM6-420-260	.165 - .260	.680	.455	.022	.390	.380	.391
5/16-18	AEKM6-518-150	.027 - .150	.690	.595	.022	.530	.470	.531
5/16-18	AEKM6-518-312	.150 - .312	.805	.595	.022	.530	.425	.531
3/8-16	AEKM6-616-150	.027 - .150	.690	.595	.022	.530	.470	.531
3/8-16	AEKM6-616-312	.150 - .312	.805	.595	.022	.530	.425	.531

All dimensions are in millimeters.

Thread Size	Part Number	Grip Range	A ±0.38	B ±0.38	C Nom.	ØD Max.	M Ref.	Hole Size In Sheet +0.15
M4 x 0.7	AEKM6-470-2.0	0.5 - 2.0	10.67	7.87	0.48	6.73	7.75	6.75
M4 x 0.7	AEKM6-470-3.3	2.0 - 3.3	11.94	7.87	0.48	6.73	7.75	6.75
M5 x 0.8	AEKM6-580-3.3	0.5 - 3.0	12.07	8.64	0.48	7.52	8	7.6
M5 x 0.8	AEKM6-580-5.7	3.0 - 5.7	14.86	8.64	0.48	7.52	8	7.6
M6 x 1	AEKM6-610-4.2	0.7 - 4.2	14.73	11.56	0.55	9.91	9.65	10
M6 x 1	AEKM6-610-6.6	4.2 - 6.6	17.27	11.56	0.55	9.91	9.65	10
M8 x 1.25	AEKM6-8125-3.8	0.7 - 3.8	17.53	15.11	0.55	13.46	11.94	13.5
M8 x 1.25	AEKM6-8125-7.9	3.8 - 7.9	20.45	15.11	0.55	13.46	10.8	13.5
M10 x 1.5	AEKM6-1015-3.8	0.7 - 3.8	17.53	15.11	0.55	13.46	11.94	13.5
M10 x 1.5	AEKM6-1015-7.9	3.8 - 7.9	20.45	15.11	0.55	13.46	10.8	13.5

Monel® is a registered trademark of Specialty Metals Corporation.

Material & Finish Specifications

Fastener Material: Monel	Finish: Tin plate
Threads: Unified, 2B per ASME B1.1	Metric: 6H per ASME B1.13M

PART NUMBER DESIGNATION

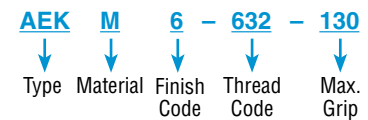

PennEngineering®

North America: Danboro, PA USA • E-mail: atlas@pemnet.com • Tel: +1-215-766-5987 • Fax: +1-215-766-5988 • 877-682-2505 (USA Only)

Europe: Galway, Ireland • E-mail: europe@pemnet.com • Tel: +353-91-751714 • Fax: +353-91-753541

Asia/Pacific: Singapore • E-mail: singapore@pemnet.com • Tel: +65-6-745-0660 • Fax: +65-6-745-2400
Shanghai, China • E-mail: china@pemnet.com • Tel: +86-21-5868-3688 • Fax: +86-21-5868-3988



Visit our PEMNET™ Resource Center at www.pemnet.com

© 2009

Specifications subject to change without notice.