

PennEngineering®

**PEMSERT® SELF-CLINCHING
FLUSH FASTENERS**



BULLETIN

F



PEMSERT® SELF-CLINCHING FLUSH FASTENERS

PEMSERT self-clinching flush nuts are designed to be completely flush in sheets as thin as 1.5 mm.

These fasteners are ideal for applications where a thin sheet requires load-bearing threads but still must remain smooth, with no protrusions on either surface. The PEM flush nut can be installed easily by squeezing it into a round hole in metal sheets. When the fastener is installed, both the top and the bottom of the sheet remain smooth, enhancing the functional and cosmetic qualities of the entire assembly. PEMSERT self-clinching flush nuts can be installed in metal sheets before bending and forming. This can provide strong threads in places which would be inaccessible for installation after chassis are formed.

The hexagonal head along with the proven PEM self-clinching design ensures high axial and torsional strength and PEMSERT Type F fasteners can be ordered to conform to US NASM45938/4 specifications.*

**To meet national aerospace standards and to obtain testing documentation, product must be ordered to NASM45938/4 specifications. Consult our Marketing department for a complete Military Specification and National Aerospace Standards Reference Guide (Bulletin NASM) or check our web site.*



PART NUMBER DESIGNATION

F - **M3** - **2**
↓ ↓ ↓
Type Thread Shank
 Size Code Code

PEMSERT® SELF-CLINCHING FLUSH FASTENERS

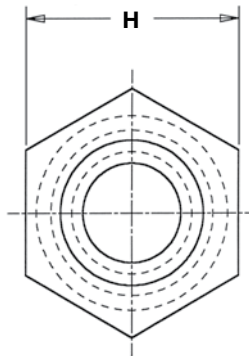

Profile for
-1 shank code.

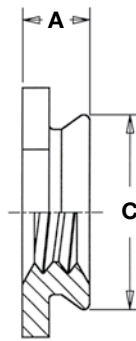

Profile for -2, -3, -4,
& -5 shank codes.

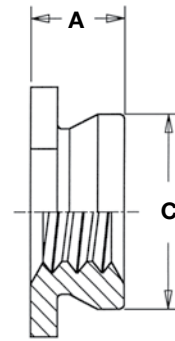

Clinching profile may vary.

All dimensions are in millimeters.

METRIC	Thread Size x Pitch	Type	Thread Code	Shank Code	A (Shank) Max.	Sheet Thickness	Hole Size In Sheet +0.08	C Max.	H Nom.	Min. Dist. Hole \varnothing To Edge
	M2 x 0.4	F	M2	1	1.53	1.53-2.3	4.37	4.35	4.8	6
				2	2.3	2.32 Min.				
	M2.5 x 0.45	F	M2.5	1	1.53	1.53-2.3	4.37	4.35	4.8	6
				2	2.3	2.32 Min.				
	M3 x 0.5	F	M3	1	1.53	1.53-2.3	4.37	4.35	4.8	6
				2	2.3	2.32 Min.				
	M4 x 0.7	F	M4	1	1.53	1.53-2.3	7.37	7.35	7.9	7.2
				2	2.3	2.32 Min.				
	M5 x 0.8	F	M5	1	1.53	1.53-2.3	7.92	7.9	8.7	8
2				2.3	2.32 Min.					
M6 x 1	F	M6	3	3.05	3.18-3.94	8.74	8.72	9.5	8.8	
			4	3.84	3.96-4.72					
			5	4.63	4.75 Min.					

THREADS: Internal, ASME B1.1, 2B / ASME B1.13M, 6H.

FASTENER MATERIAL: 300 Series Stainless Steel.

FINISH: Passivated and/or tested per ASTM A380.

FOR USE IN SHEET HARDNESS: HRB 70 / HB 125 or less.

HRB - Hardness Rockwell "B" Scale. HB - Hardness Brinell.

PEMSERT® SELF-CLINCHING FLUSH FASTENERS

INSTALLATION

1. Prepare properly sized round mounting hole in sheet. Do not perform any secondary operations such as deburring.
2. Place shank of fastener into mounting hole (preferably the punch side).
3. With punch and anvil surfaces parallel, apply sufficient squeezing force only to embed hexagonal head flush in sheet. The metal displaced by the head flows evenly and smoothly around the back-tapered shank of the fastener, securely locking it into place with high pullout resistance while at the same time, the embedded hexagonal head provides high torque resistance.

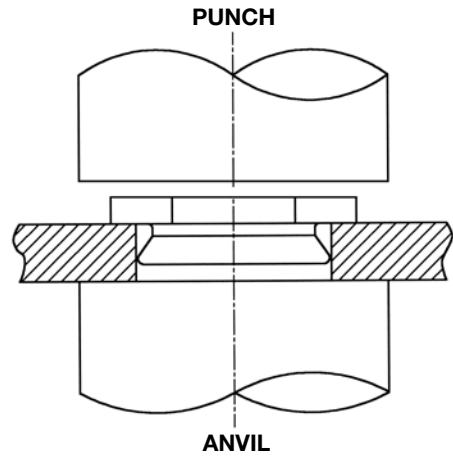

PERFORMANCE DATA⁽¹⁾

METRIC	Thread Code	Shank Code	Axial Tensile Strength (2) (kN)	Max. Screw (3) Tightening Torque (N•m)	Test Sheet Material			
					5052-H34 Aluminum		Cold-rolled Steel	
					Installation (kN)	Pushout (N)	Installation (kN)	Pushout (N)
M2	1	2	0.57	0.16	8.9	890	13.3	890
		1						
M2.5	1	2	0.68	0.23	8.9	890	13.3	890
		1						
M3	1	2	0.85	0.36	8.9	890	13.3	890
		1						
M4	1	2	1	0.58	8.9	1068	17.8	1068
		1						
M5	1	2	1.3	0.88	11.1	1068	17.8	1068
		1						
M6	3	4	4.5	3.7	15.6	2847	20	3736
		5						
		1						

- (1) The values reported are averages when all installation specifications and procedures are followed. Variations in mounting hole size, sheet material and installation procedure will affect results. Performance testing of this product in your application is recommended. We will be happy to provide samples for this purpose.
- (2) Failure occurs in screw stripping using a 60 ksi screw and the shortest shank length fastener.
- (3) Head of the F nut may bend and/or fail if screw is over-torqued beyond these values.

RoHS compliance information can be found on our website.
© 2011 PennEngineering.

Specifications subject to change without notice.
See our website for the most current version of this bulletin.

PennEngineering®



North America: Danboro, PA USA • E-mail: info@pemnet.com • Tel: +1-215-766-8853 • Fax: +1-215-766-0143 • 800-237-4736 (USA Only)
Europe: Galway, Ireland • E-mail: europe@pemnet.com • Tel: +353-91-751714 • Fax: +353-91-753541
Asia/Pacific: Singapore • E-mail: singapore@pemnet.com • Tel: +65-6-745-0660 • Fax: +65-6-745-2400
 Shanghai, China • E-mail: china@pemnet.com • Tel: +86-21-5868-3688 • Fax: +86-21-5868-3988

Visit our PEMNET™ Resource Center at www.pemnet.com

Technical support e-mail: techsupport@pemnet.com